

HOLITA SPCM-S-APD

Single Photon Counting Module Count Series

Description

HOLITA' newly improved SPCM-L-APD series Single Photon Counting Module APD operated in the Geiger mode, are used to detect single photons over the wavelength range of 350nm to 1060nm. The SPCM-L-APD series has been developed to offer a unique combination of high quantum efficiency, wide dynamic range and ease of use for photon counting applications.

A TTL-level pulse is generated for each photon detected and the signal is available over the RF wire with SMB male connector at the rear of the module. The signal should be terminated into 50Ω. The gating function allows the module to be disabled between measurements to provide protection against accidental overload.

The photodiode is both thermoelectrically cooled and temperature controlled, ensuring stabilized performance despite ambient temperature changes. Operating temperature range has been increased and the module (case temperature) will operate from -20°C to 50°C.

The dead time of the SPCM-L-APD is approximately 33ns, thereby increasing linearity and improving the dynamic range of the module. Timing resolution of the module was also improved significantly.

The SPCM-L-APD has very high Photon Detection Efficiency (PDE) from blue range to yellow range.

The SPCM-L-APD operated in the Geiger mode, so the detector provides gains of up to 10^6 – 10^8 .



Key Feature

- Low dark count rates
- Peak PDE:
 - >50% @410nm
 - >60% @532nm
 - >60% @830nm⁽¹²⁾
- >24 MC/S dynamic range
- Gate input
- Single +12V DC supply
- Optional FC fiber connector

Applications

- LIDAR
- Particle sizing
- Optical range finding
- Fluorescence analysis
- Astronomy observation
- Quantum Cryptography
- Ultra-sensitive fluorescence
- Photon correlation spectroscopy

Table 1 Specifications of SPCM-S-APD-ACE, @25°C, all models, unless otherwise indicated.

Parameter	Min	Typ	Max	Unit
Supply voltage ⁽¹⁾	11.5	12	12.5	V
Supply current		0.1	0.2	A
Case operating temperature ^(1,2)	-20		70	°C
Active area diameter		500		µm
Active area		0.2		mm ²
Photon detection efficiency (PDE)				
405nm ⁽¹¹⁾	50	55		%
532nm ⁽¹¹⁾	60	70		%
670nm ⁽¹¹⁾	50	55		%
830nm ⁽¹²⁾	45	55		%
Dark Count ^(3,4)				
SPCM-L-APD-A0E			1500	Counts / second (CPS)
SPCM-L-APD-A1E			1000	
SPCM-L-APD-A2E			500	
SPCM-L-APD-A3E			250	
SPCM-L-APD-A4E			100	
SPCM-L-APD-A5E			50	
SPCM-L-APD-A6E			25	
Output pulse width ⁽⁵⁾	8	10	12	ns
Dead time ⁽⁶⁾				
SPCM-L-APD-Axx		33		ns
SPCM-L-APD-Bxx		47		ns
Output pulse amplitude ⁽⁷⁾ @1K Ohm(50 Ohm)				
TTL HIGH	4(2)	4.4(2.2)		V
TTL LOW			0.8	V
Single photon timing resolution ⁽⁸⁾		500	800	ps
Afterpulsing probability ⁽⁹⁾		2		%
Setting time following power up(1% stability) at 1Mc/s and 25°C		15	20	S
Output count rate before saturation ⁽¹⁰⁾		24		Mc/s
Gating threshold voltage				
Low level	0		0.4	V
High level	2.4		5.25	V
Gating turn on/off input				
Disable = TTL low(<0.4V)		40	45	ns
Enable = TTL high(>2.4V)		50	65	ns

1. Connection to incorrect voltage or reverse voltage may damage or destroy the module. The warranty is invalid should such damage occur.
2. The module dissipates a mean power of 2.0W and a maximum power of 6W at high count rate and over 70°C. Adequate heat sinking must be provided by clamping the module to a suitable heat sink via the holes in the module base. To meet specified performance, the module case temperature must not exceed 70°C. To get best performance, the module case temperature must not exceed 50°C.
3. On a small percentage of delivered modules, bi-stability of the dark count has been observed. Research indicates this bi-stability is probably due to transitions at a single impurity site between a low energy and a high energy state.
4. In the dark, the module generates random counts that follow a Poisson distribution. In a poisonings process, the standard deviation is equal to the square root of the average count. In this specification the “dark count variation” refers to the stability of the average count of the module.
5. Output pulse width is set at the standard of 10ns ± 2ns at 2.2V with 50ohm load.
6. The dead time of SPCM-L-APD-Axx is 33ns and the dead time of SPCM-L-APD-Bxx is 47ns; The actual photon rate could be calculated using the following equation, as indicated in Note #6 in the box below:

Note #6: [Actual photon rate calculation formula](#)

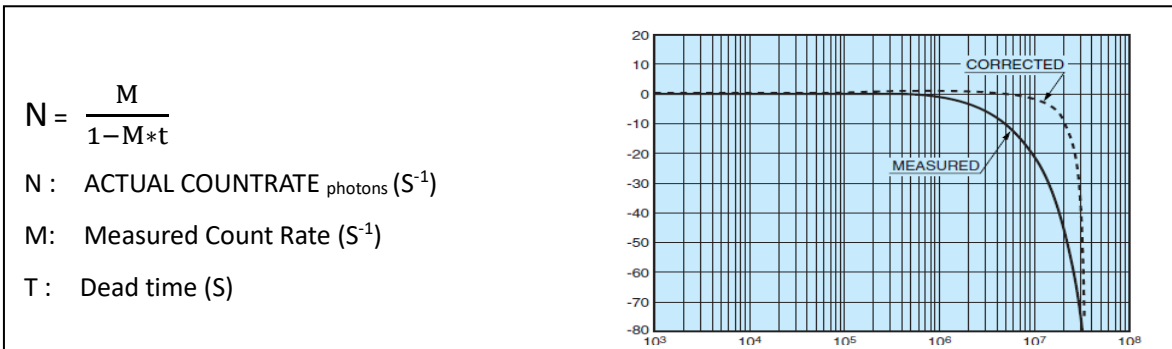

7. Output pulse height standard is set to 4.4V ± 0.4V when un-terminated.
8. Timing resolution depends on count rate and wavelength. Timing resolution is measured using a less than 10µm diameter light spot.
9. Defined at 5% photon detection probability (830nm), After-pulse occurring 1us to 60 seconds after main pulse.
10. For the typical dead time setting of 33ns, typical maximum count rate is 24Mc/s before saturation. If the maximum dead time setting is used, about 62ns, typical maximum count rate would be about 12Mc/s. Note that using a longer dead time will degrade linearity.
11. With the module SPCM-L-APD-Axx.
12. With the module SPCM-L-APD-Bxx.

Table 2 Absolute Maximum Rating

Supply Voltage ⁽¹⁾	220VAC
Maximum count rate	Maximum count rate can be sustained if case temperature is maintained within limit specified limits
Peak light intensity	maximum 10^4 photons / pulse, light pulse width < 1ns
Case temperature ⁽²⁾	-20°C/+85°C storage, -20°C /+50°C operating

Figure 1 SPCM-S-APD Module Block Diagram

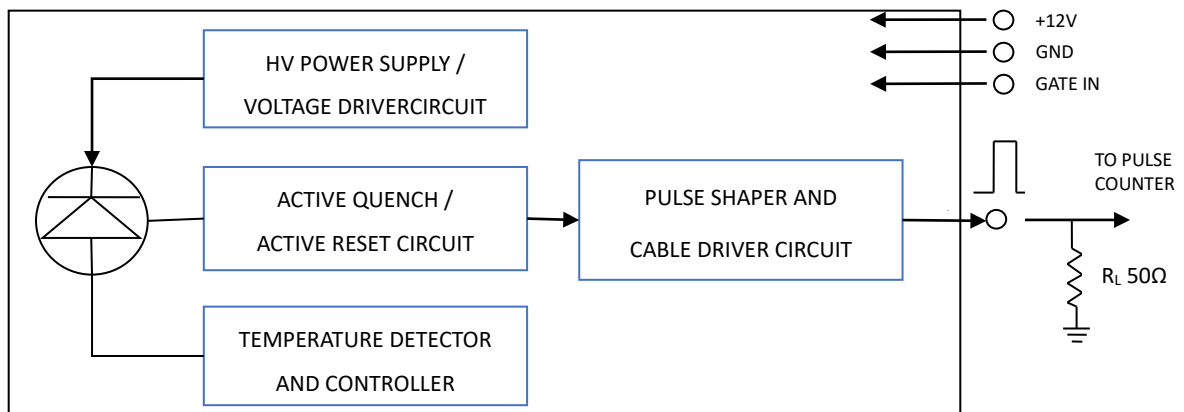

Figure 2 SPCM-S-APD Modules Electrical Connections

OUTPUT CONNECTOR

The digital OUTPUT pulse (blue wire, TTL levels, >1.5V) should be terminated into a 50Ω load to avoid distortion and ringing. A 1.0V triggering level is recommended on counters and oscilloscopes to avoid triggering on noise. Note that TTL stands for Transistor-Transistor Logic.

GATE CONNECTOR (optional)

The GATE input (green wire) impedance is internally connected to the +5 volt supply through a 10KΩ pull-up resistor (standard module versions). It can be driven by standard TTL level signals. Operation: TTL high – module counts, TTL low – counting disabled.

POWER CONNECTOR

Connection to incorrect voltage or reverse voltage may damage or destroy the module. The warranty is invalid should such damage occur.

Figure 3 Typical Photon Detection Efficiency (PDE) vs. Wavelength (SPCM-S-APD-ACE)

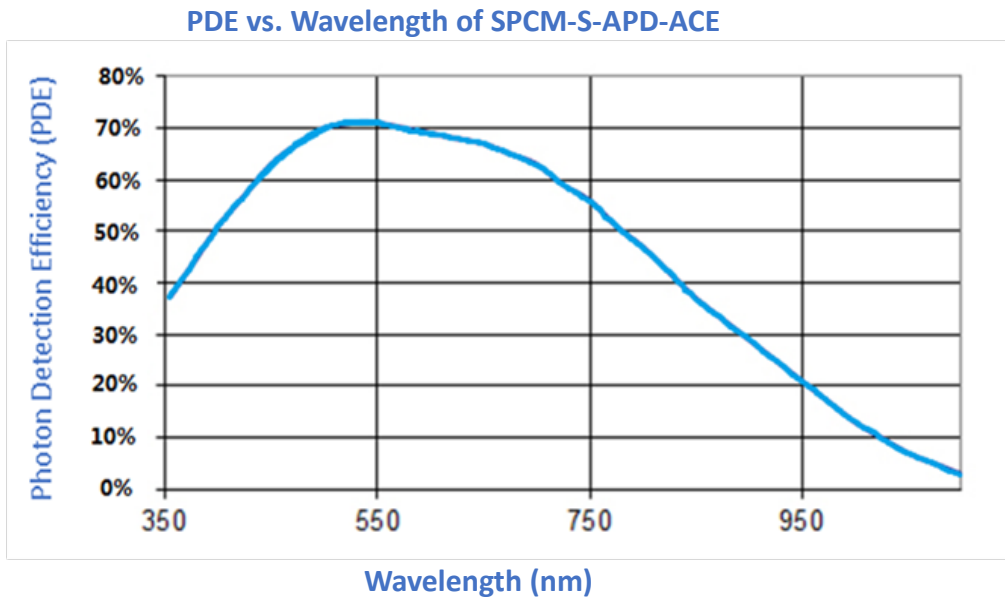

Figure 4 Typical Photon Detection Efficiency (PDE) vs. Wavelength (SPCM-S-APD-BCE)

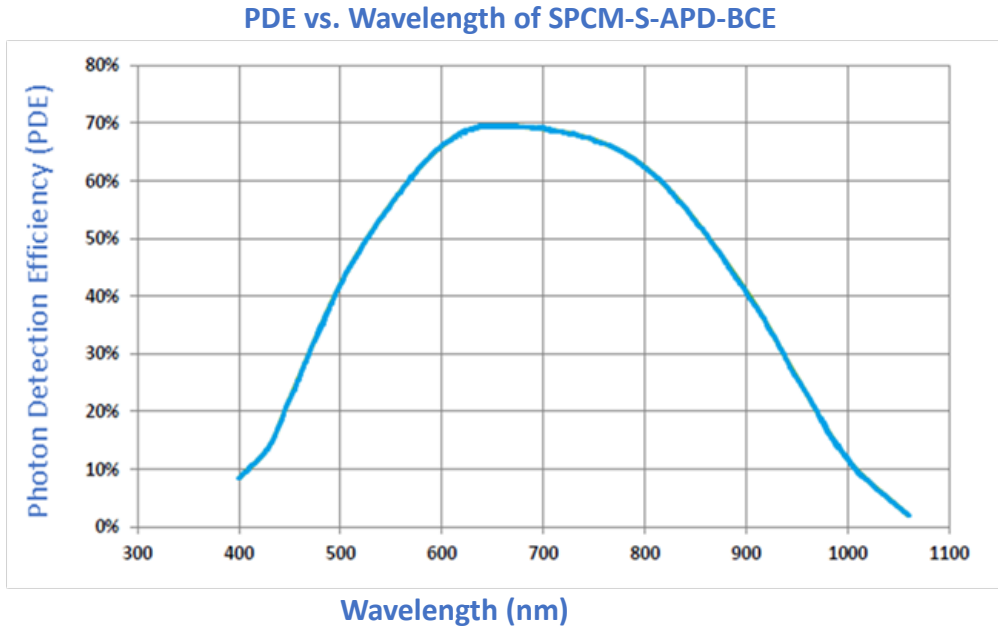

Figure 5 Beam diameter on detector surface vs. relative intensity of PDE referring to maximum value

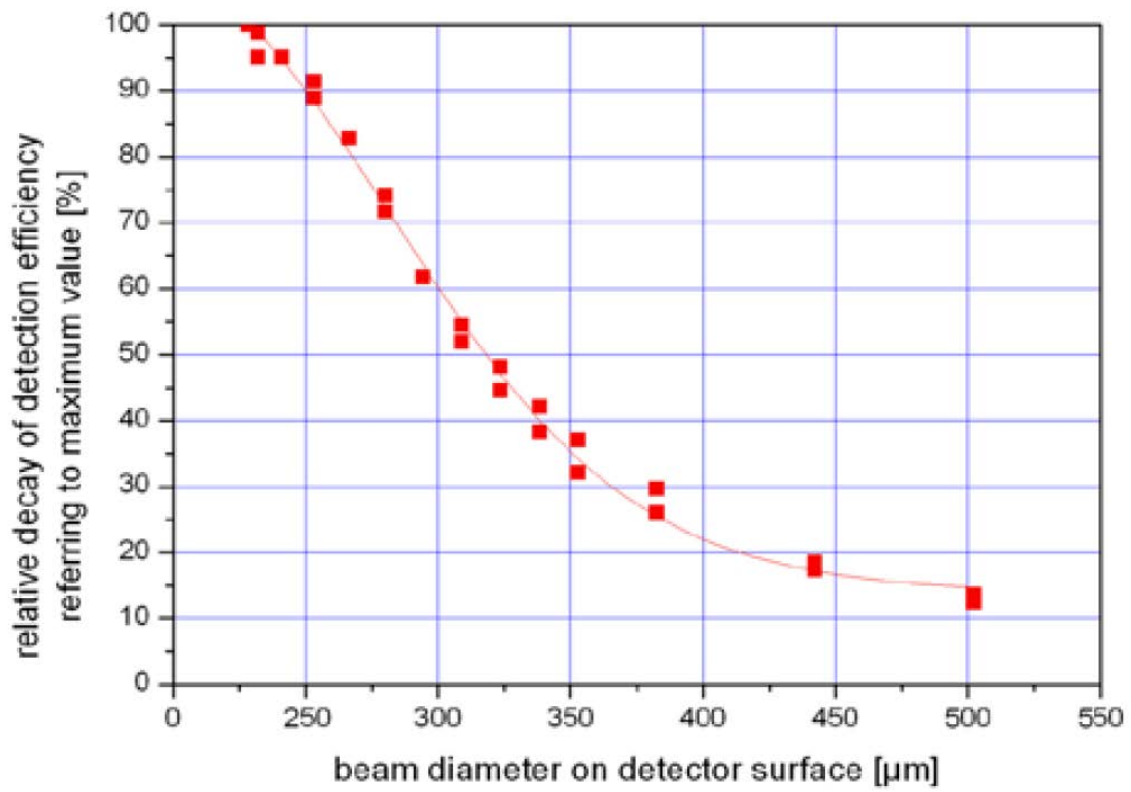

Figure 6 Optical Power vs. Number of Photons

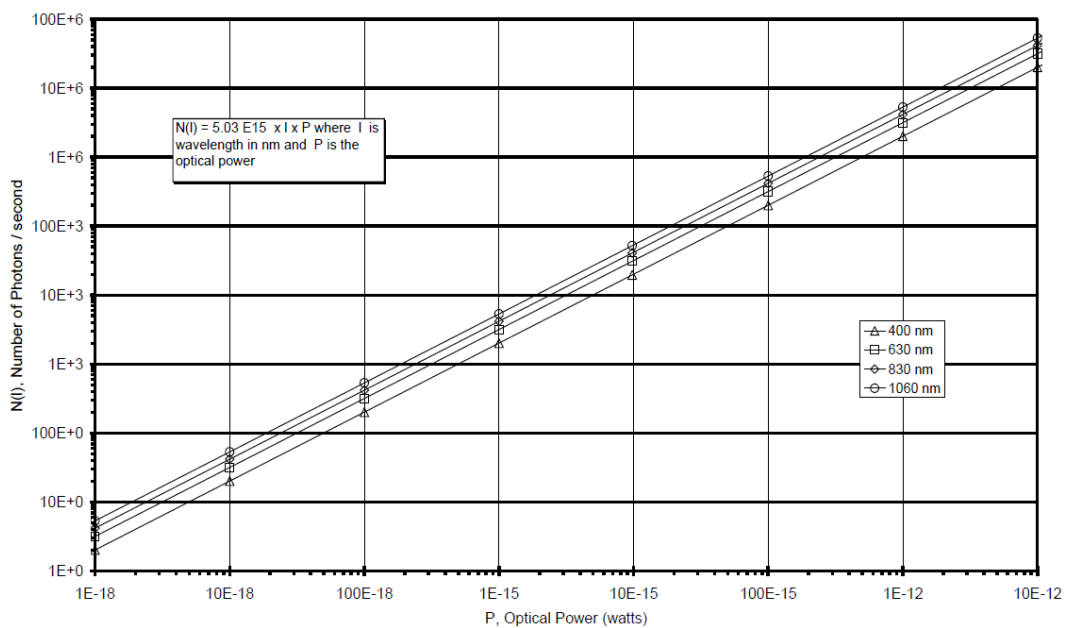

Figure 7 Dimensional Outline (unit: mm)

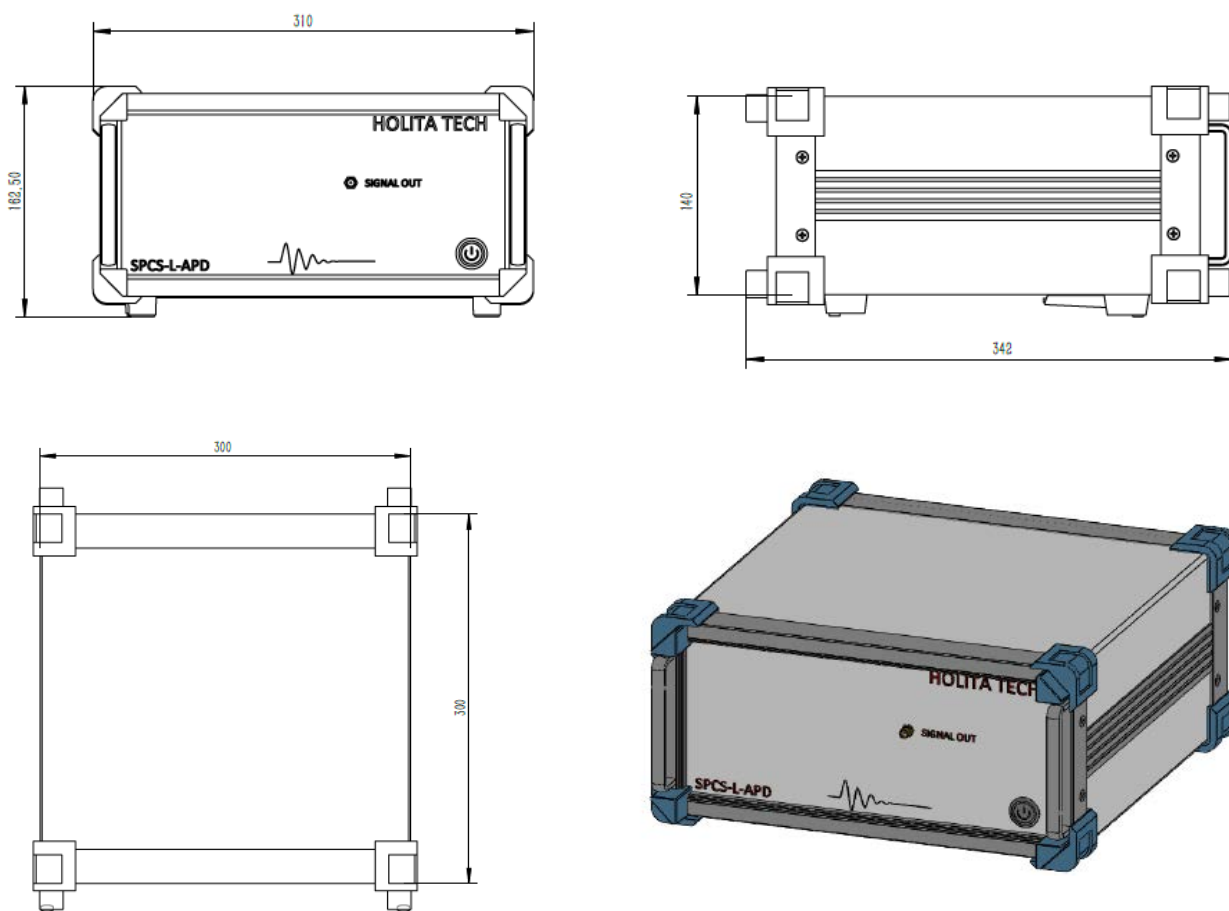
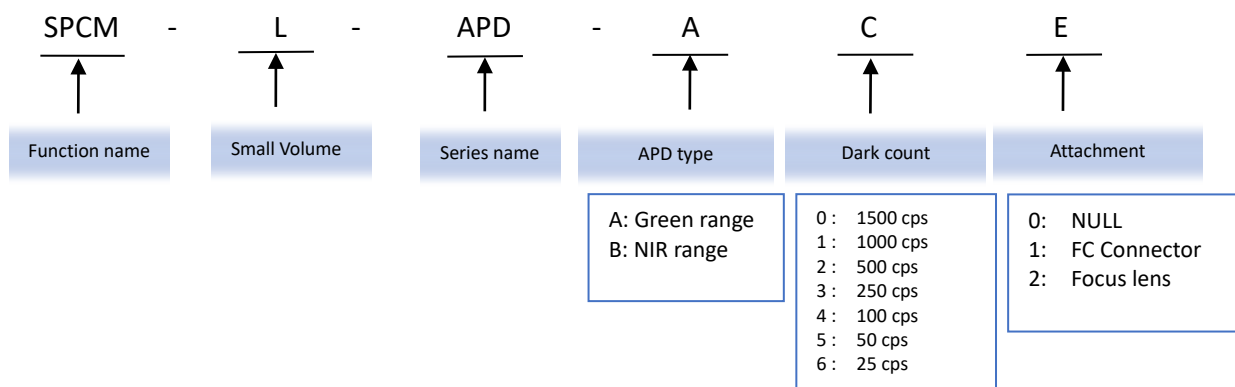

Figure 8 SPCM-L-APD Ordering Guide



Gating Function

A gating function is provided with each module – useful for viewing a signal that occurs only in a small timeframe window. Also, in some applications the background light flux is higher than the signal. In this case, the gating option could be used to improve the S/N ratio by opening a window only when the light signal is present. The output of the module and the active quench function are disabled when a TTL low level is applied to the module gate input. When a TTL high level is applied to the module gate input, the output of the module and the active quench circuit is enabled again. Any photon detection that occurs less than 2 μ s before the module gate input changes can result in an output pulse. If the gating input is left unconnected, the module is enabled by default.

Saturation

The photon count rate decreases at high incoming light levels. The count at which the output rate starts to decrease is called the saturation point. As an extreme example, if the module is exposed to intense light the count rate will fall to zero. While the module is protected against light overload, precautions should be taken to avoid any excessive light level that will damage the SPCM module. After an over exposure, the dark count of the module could increase temporarily for up to an hour. For faster recovery, it is recommended to power off the module and leaves it in the dark for one to two minutes prior to restarting.

Safety Warning



The SPCM-S-APD contains a high voltage power supply. Users may be injured if the case is opened. All internal settings are pre-set; there are no user adjustments.



Units that appear defective or have suffered mechanical damage should not be used because of possible electrical shorting of the high voltage power supply. Opening the case may damage sensitive components and expose the user to the risk of electrical shock. Please contact factory for repairs.

Warranty

A standard 12-month warranty following shipment applies. Any warranty is null and void if the module case has been opened. Warranty is null and void if the module input exceeds 13 V or the polarity of the +12V supply is reversed.

ESD Warning

Modules should only be handled at an ESD-safe work station.

Ordering information

Products can be ordered directly from HOLITA or its representatives. For a complete listing of representatives, visit our website at www.holita.cn. Custom designed products are available on request.